

Operating Instructions

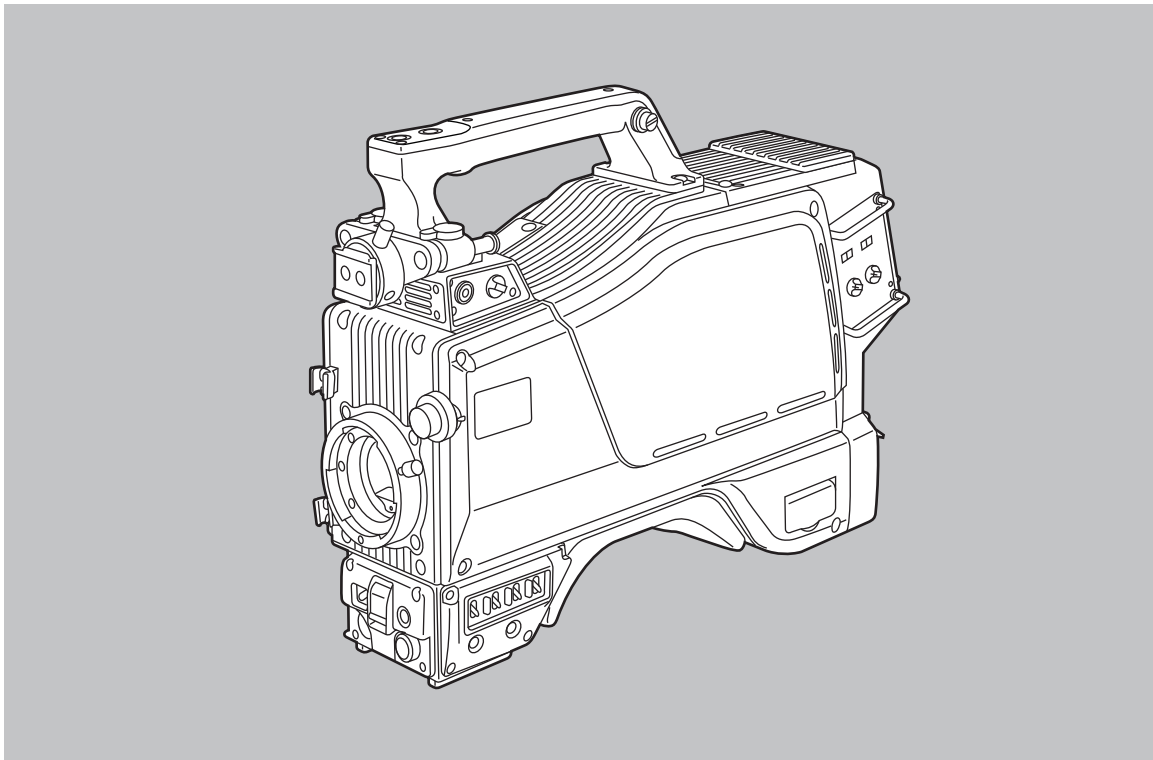

Multi-Format Camera
Model AK-HC930P



Panasonic[®]

Before attempting to connect, operate or adjust this product, please read these instructions completely.

For your safety

	CAUTION RISK OF ELECTRIC SHOCK DO NOT OPEN	
CAUTION: TO REDUCE THE RISK OF ELECTRIC SHOCK, DO NOT REMOVE COVER (OR BACK). NO USER SERVICEABLE PARTS INSIDE. REFER TO SERVICING TO QUALIFIED SERVICE PERSONNEL.		



The lightning flash with arrowhead symbol, within an equilateral triangle, is intended to alert the user to the presence of uninsulated "dangerous voltage" within the product's enclosure that may be of sufficient magnitude to constitute a risk of electric shock to persons.



The exclamation point within an equilateral triangle is intended to alert the user to the presence of important operating and maintenance (service) instructions in the literature accompanying the appliance.

WARNING:

TO REDUCE THE RISK OF FIRE OR SHOCK HAZARD, DO NOT EXPOSE THIS EQUIPMENT TO RAIN OR MOISTURE.

CAUTION:

TO REDUCE THE RISK OF FIRE OR SHOCK HAZARD AND ANNOYING INTERFERENCE, USE THE RECOMMENDED ACCESSORIES ONLY .

For CANADA

**This class A digital apparatus complies with Canadian ICES-003.
Cet appareil numérique de la classe A est conforme à la norme NMB-003 du Canada.**

This product contains a CR Coin Cell Lithium Battery which contains Perchlorate Material — special handling may apply.
See www.dtsc.ca.gov/hazardouswaste/perchlorate.

FCC Note:

This device complies with Part 15 of the FCC Rules. To assure continued compliance follow the attached installation instructions and do not make any unauthorized modifications.

This equipment has been tested and found to comply with the limits for a class A digital device, pursuant to Part 15 of the FCC Rules. These limits are designed to provide reasonable protection against harmful interference when the equipment is operated in a commercial environment. This equipment generates, uses, and can radiate radio frequency energy and, if not installed and used in accordance with the instruction manual, may cause harmful interference to radio communications. Operation of this equipment in a residential area is likely to cause harmful interference in which case the user will be required to correct the interference at his own expense.

CAUTION:

**Invisible Laser radiation is emitted from the Optical fiber connector when this product is turned on.
Don't look into directly into the Optical fiber connector of this product.**

CAUTION:

This product uses a semiconductor laser system and is a laser class 1 product complies with Radiation Performance Standards, 21CFR SUBCHAPTER J.
Use of controls or adjustments or performance of procedures other than those specified herein may result in hazardous radiation exposure.
Don't make any modifications.
Don't repair by yourself.
Refer servicing to qualified personnel.

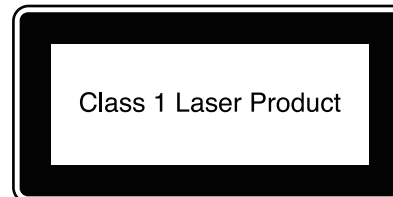

 indicates safety information.

Contents

For your safety	2
Overview	4
Features	4
Controls and their functions	5
Mounting the lens	10
Adjusting the lens flange back	11
Performing the viewfinder adjustments	12
Connecting the microphone	14
Mounting the camera on a tripod	15
Component system configuration	16
System connections 1 (with Multi-Format Camera)	18
System connections 2 (with build-up unit)	19
System connections 3 (with MSU)	20
Status displays on viewfinder screen	21
Menu operations	22
Setting menu configuration	24
AK-HC930P Connector pin assignment	27
External dimension drawings	28
Specifications	29

Overview

This new-generation all-format HD camera is designed to support the 1080I format.

By way of providing support for the 1080I format, this model uses newly developed 2/3" CCDs with 2.2 million pixels [1920 (H) x 1080 (V)]. By taking a fresh approach to the on-chip lens, CCD structure and processes, these new CCDs embody dramatically improved sensitivity, smear and dynamic range specifications compared with conventional CCDs, and they achieve a high performance which is on a par with that of SD. Furthermore, the moire in the band has been slashed by offsetting the pixels by combining Panasonic's unique horizontal line readout CCDs with high-accuracy signal processing.

The newly developed digital signal processing LSI which supports 12-bit A/D conversion and which is provided in the camera head processes the gamma, knee, detail, matrix and other process signals and uses a new system for CCD defect correction to achieve improved operability with a greater number of functions, high quality and high stability which only digital systems can deliver. The 12-bit A/D converter yields a stable wide dynamic circuit with a high signal-to-noise ratio from the dark areas to the highlights.

A newly developed casing is used to house the Multi-Format Camera head to achieve a compact size and light weight. The amount of heat generated has been significantly reduced by designing the new circuitry to consume less power and by adopting an efficient heat dissipation design for the new casing.

SD signals (D1, VBS) can be output and RET images and PROMPT signals can be input by connecting the Multi-Format Camera to the CCU (AK-HCU931P, optional accessory).

In terms of controlling the camera's functions, the ROP (AK-HRP931P) or MSU (AK-MSU930P), also available as an optional accessory, can be connected to the CCU to control such analog functions as the camera head's pedestal and iris and control such switches as the gain and output selector switches.

Features

Newly developed 1080I, 2.2 million-pixel CCDs incorporated

- This achieves a high sensitivity that surpasses the standard sensitivity of F10 and is on a par with SD.
- Smear has been cut to 135 dB and the number of white marks has been drastically reduced by process improvements.
- H-CCD drive is accomplished at a frequency of 74 MHz to attain a high response and high resolution.

Digital signal processing LSI with high picture quality featured in the camera unit

- After the process circuits, the signals undergo 12-bit, 74 MHz high-picture-quality digital processing, yielding a high reliability, more functions and enhanced operating ease as a result.

Multi-functional enhancer

- In addition to the many functions such as chroma DTL, skin DTL and dynamic DTL, there is a choice of 8 boost frequencies. (For both HD and SD)

Designed to achieve low noise levels of below NC15

- The fan mode can be switched to suit the application at hand, and measures to reduce the power requirements and improve the heat dissipation were adopted in the final design.

Fuller complement of control circuits and auto setup (ASU) function

- The self-diagnosis functions have been enhanced, and it has now become possible to select the ASU function by combining the external shooting chart and internal test signals as well as the normal, simplified or other mode.

Peripheral components

- Ease of operation can be further improved by configuring a system where the Multi-Format Camera is used in combination with the remote operation panel (ROP) and master setup unit (MSU).
- Using the ROP matrix, for instance, ROP assignment is enabled without connector patch switching.

Data trunk function

- Two RS-422 circuits are provided as a standard feature. They obviate the need for the cables used with virtual control, pan-tilt head and lens control, etc.

D/C output of camera supported (optional function)

- The VF output or camera output can be selected as the D/C output.
- The VF images can be monitored on the NTSC LCD monitor.

Controls and their functions

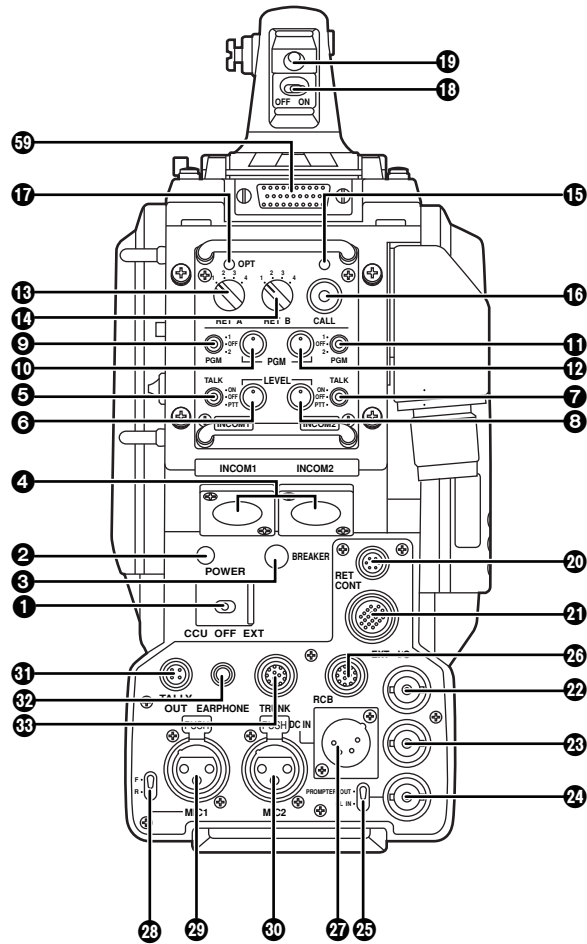
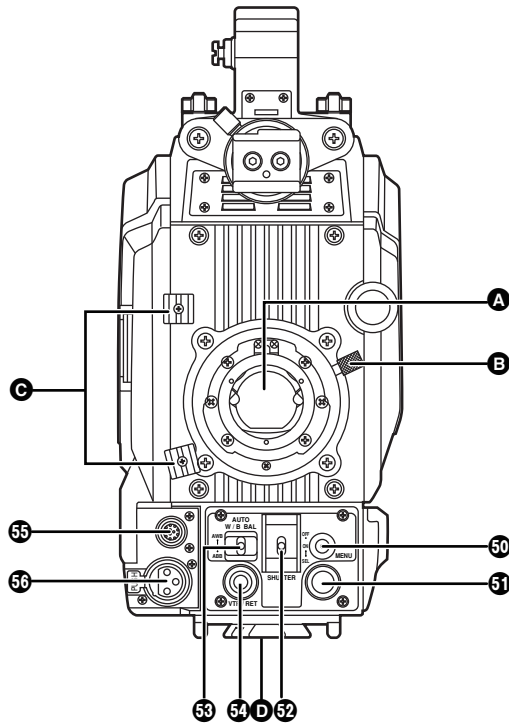

Controls and their functions

- A Lens mount (Bayonet type)**
This is where the lens is mounted.
- B Lens clamp lever**
The lens is inserted into the lens mount **A**, and this lever is then turned to clamp the lens in place.
- C Lens cable, mic cable clamps**
These are used to clamp the lens cable and mic cable in place.
- D Tripod mount**
Before securing the Multi-Format Camera to a tripod, attach the tripod adapter (SHAN-TM700) which is available as an optional accessory.
- E Shoulder pad**
Adjust this pad in such a way that the Multi-Format Camera can be operated easily when carried on the shoulder.
The pad position can be moved forward or backward once the two fixing screws are loosened.
- F Optical fiber connector (EDW.3K made by LEMO)**
- 1 Camera power switch [POWER]**
This is used to select the camera power input (power supplied from the CCU or from an external connector) and turn the power ON and OFF.
- 2 Power LED**
This lights up red when power is supplied to the camera.
- 3 Power circuit breaker [BREAKER]**
When an overcurrent flows to the camera, the breaker is tripped, and the power supply is cut off.
- 4 INCOM connectors 1, 2 [INCOM1, INCOM2]**
The INCOM or headset plugs are connected here.
- 5 INCOM1 MIC ON/OFF switch [MIC1 TALK]**
This is the INCOM1 MIC ON/OFF selector switch.
- 6 INCOM1 level control [INCOM1 LEVEL]**
This is used to adjust the INCOM1 receive level.
- 7 INCOM2 MIC ON/OFF switch [MIC2 TALK]**
This is the INCOM2 MIC ON/OFF selector switch.
- 8 INCOM2 level control [INCOM2 LEVEL]**
This is used to adjust the INCOM2 receive level.
- 9 INCOM1 PGM selector switch [INCOM1 PGM]**
This is used to select the PGM to be mixed with INCOM1.
- 10 INCOM1 PGM level control [INCOM1 PGM]**
This is used to adjust the INCOM1 and PGM mixing level.
- 11 INCOM2 PGM selector switch [INCOM2 PGM]**
This is used to select the PGM to be mixed with INCOM2.
- 12 INCOM2 PGM level control [INCOM2 PGM]**
This is used to adjust the INCOM2 and PGM mixing level.
- 13 RET-A selector switch [RET A]**
This switch is used to select the return images to be switched by RET-A.
- 14 RET-B selector switch [RET B]**
This switch is used to select the return images to be switched by RET-B.
- 15 CALL LED**
This lights when the CALL switch is pressed. It also lights in response to a call from the ROP or MSU.
- 16 CALL switch [CALL]**
This lights the CALL LED on the ROP or MSU and sounds the buzzer.
- 17 OPT LED**
This indicates the camera's optical signal reception status. It normally lights up green. When any problem has occurred, it lights up red.
- 18 Back tally LED selector switch**
This is used to set the back tally LED to ON or OFF.
- 19 Back tally LED**
This lights when the tally signal is supplied.
- 20 RET switching control connector [RET CONT]**
The cable of the RET switching box (optional accessory) is connected here for controlling the ON/OFF settings of RET1, 2, 3 and INCOM1 MIC.
- 21 Build-up unit connector [EXT I/O]**
The cable from the build-up unit (optional accessory) is connected here.
- 22 Camera main line SDI output connector (BNC) [HD SDI]**
The camera main line's HD-SDI images are output from this connector.
- 23 Optional video output connector (BNC) [AUX OUT]**
When the camera D/C unit (AK-HDC931, optional accessory) has been installed, the camera's D/C images (VBS) are output from this connector.
- 24 Genlock sync input/PROMPT output connector [PROMPT/GL]**
When the GL/PROMPT selector switch is set to GL, the reference signal (tri-level SYNC) which is used to genlock the camera is input to this connector; when it is set to PROMPT, the images input from the CCU are output from this connector.
- 25 GL/PROMPT selector switch**
This is used to select the genlock input or the input/output (genlock input and PROMPT output) signals of the PROMPT output connector.

Controls and their functions

- 26 RCB connector [RCB]**
The simplified remote control unit (RCB, optional accessory) is connected to this connector.
- 27 External power supply input connector [DC IN]**
The input of the external DC power supply is connected to this connector. (DC 12V)
- 28 MIC1 selector switch [MIC1 F/R]**
This is used to switch the MIC1 input signal to the front or rear.
- 29 Rear MIC1 connector [MIC1]**
An audio component or microphone is connected to this connector.
- 30 Rear MIC2 connector [MIC2]**
An audio component or microphone is connected to this connector.
- 31 Tally output connector [TALLY OUT]**
The R or G tally signal is output from this connector (open collector). A DC 12 V voltage (approx. 1.0 A) can also be supplied.
- 32 Earphone jack [EARPHONE]**
When an earphone (optional accessory) is connected to this jack, the INCOM1 receive signal and MIC1 monitor signal can be heard.
- 33 Data trunk connector [TRUNK]**
The trunk data [RS-422 x2] of the CCU is input to and output from this connector.
- 34 MIC1 power selector switch**
This is used to select what kind of power is to be supplied to MIC1. (The switch is set to phantom 48 V, AB 12 V or OFF.)
- 35 MIC2 power selector switch**
This is used to select what kind of power is to be supplied to MIC2. (The switch is set to phantom 48 V, AB 12 V or OFF.)
- 36 Input gain selector switch**
This is used to set the MIC1 input gain (in 10 dBm increments from -20 to 60 dBm).
- 37 MIC2 input gain selector switch**
This is used to set the MIC2 input gain (in 10 dBm increments from -20 to 60 dBm).
- 38 RET selector switch [RET]**
This is used as return image selector switch.
- 39 Optical filter selector switch [FILTER LOCAL]**
This is pressed to adjust the optical filter manually. When it is pressed again, the optical filter can be controlled by the ROP.
- 40 Monitor output selector switch [MONI SEL]**
This is used to select the images (Y, NAM, R, G, B) which are to be output from the monitor output connector.
- 41 ND filter selector knob**
This is used to adjust the optical filter manually when LOCAL has been selected as the filter setting.
1: CAP, 2: Through, 3: 1/4, 4: 1/16, 5: 1/64
- 42 CC filter selector knob**
This is used to adjust the optical filter manually when LOCAL has been selected as the filter setting.
A: 3200K, B: 4300K, C: 6300K, D: Cross, E: DFO
- 43 Power save switch [CAM/VTR]**
This is used to select the power supply status when VTR recording has been temporarily stopped. It is not effective when the CCU is connected to the camera.
- 44 Gain selector switch [GAIN]**
This is used to select the gain for the camera images. It is not effective when the CCU is connected to the camera.
- 45 Camera output selector switch [OUTPUT]**
This is used to select the video output (CAM, BAR or TEST). It is not effective when the CCU is connected to the camera.
- 46 White balance selector switch [W.BAL]**
This is set when there is no time to perform the coarse adjustment of the white balance. It is not effective when the CCU is connected to the camera.
- 47 PTT switch [PTT]**
This selector switch is used to set the INCOM1 MIC to ON or OFF.
- 48 Assignable switch [USER SEL]**
Using the setting menu, user settings can be assigned to this switch. When the switch is pressed, the assigned user setting mode is established; when it is pressed again, the selected mode is released.
- 49 SD card connector [SD CARD]**
The setup card (optional accessory) is inserted here. For details on its operation, refer to the menu.
- 50 Menu switch [MENU]**
When this switch is pressed, the camera's user menu is output; when it is pressed again, the menu screen display is cleared.

Controls and their functions

51 JOG dial button

Turning the JOG dial while the menu screen is displayed moves the cursor to the setting items. The menu settings are established by operating this dial button.

For details on the menu operations, refer to the section on the menu operations.

52 Electronic shutter selector switch [SHUTTER]

This is set to ON when the electronic shutter is to be used. When it is set to the SEL position, the shutter speed is switched in the preset range and the mode is also switched. It is not effective when the CCU is connected to the camera.

53 AWB/ABB start switch [AUTO W/B BAL]

This switch is operated when the white balance (AWB) or black balance (ABB) is to be adjusted automatically. It is not effective when the CCU is connected to the camera.

54 VTR start/RET selector switch [VTR/RET]

This is used as the REC start switch of the VTR and return image selector switch. It performs the same operations as the VTR button of the lens. Its function can be allocated as desired on the menu.

55 Lens connector [LENS]

The lens cable is connected to this connector.

56 Front MIC1 connector [MIC1]

A microphone (optional accessory) is connected here.

The power supply for the microphone can be connected from this connector. What kind of power is to be supplied is set using the MIC1 power selector switch.

57 VF connector [VF]

The viewfinder cable is connected to this connector.

58 Monitor output connector (BNC) [MONITOR OUT]

The video signals for the monitor are output from this connector. The images to be output are selected using the monitor output selector switch.

59 Rear VF connector

This D-sub connector is used for Viewfinder interface.

Mounting the lens

- 1** Raise the lens clamp lever, and remove the mount cap.

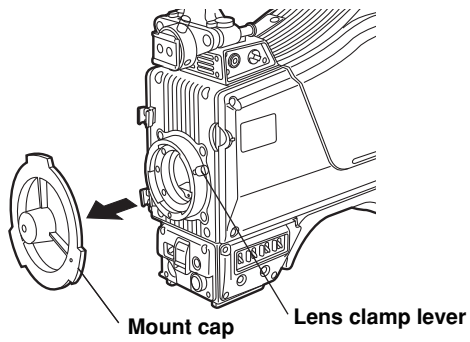

- 4** Insert the cable into the cable clamp and connect it to the LENS connector.

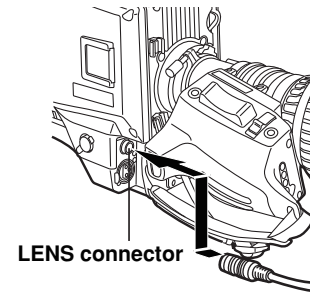

- 2** Align the center mark on the lens with the groove at the top center of the lens mount, and mount the lens.

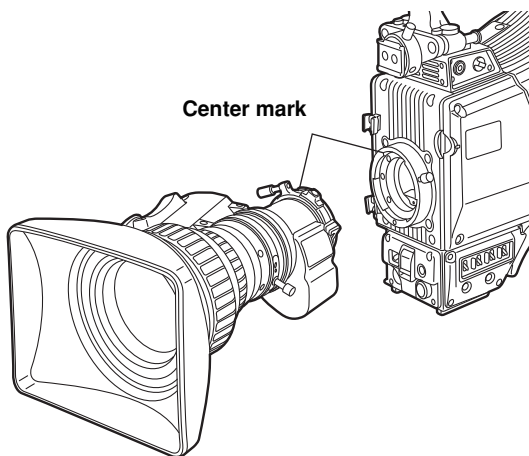

- 3** Lower the lens clamp lever to clamp the lens in place.

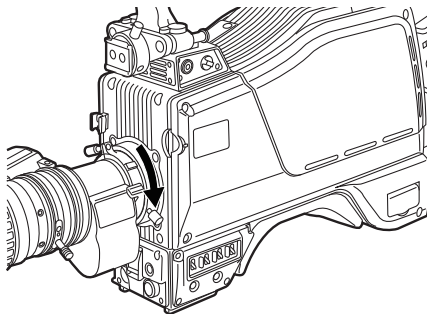

<Notes>

- For details on handling the lens, refer to the instructions that accompany the lens.
- Depending on the lens mounted, it may be necessary to perform the following lens and camera adjustments.
 1. Flange back adjustment for the lens
 2. Auto iris operation speed adjustment for the lens
 3. White shading adjustment for the lens (performed using the controls on the camera)

Adjusting the lens flange back

Adjust the flange back (distance from the surface where the lens is mounted to the surface where the images are formed) if the subject fails to be precisely focused at both the telephoto and wide-angle settings when zoom operations are to be performed.

Once adjusted, the flange back does not need to be adjusted again unless the lens is replaced.

Adjustment method

<Note>

For details on the adjustment method and positions of the lens parts, refer also to the instructions that accompany the lens.

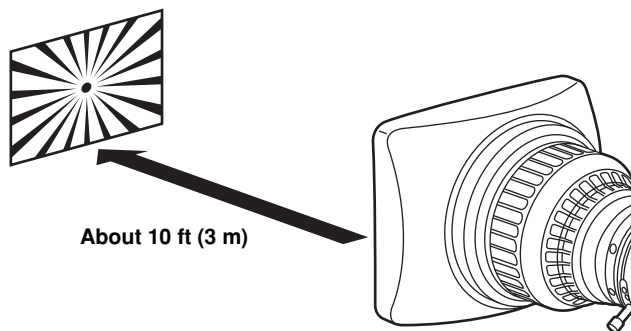

- 1** Mount the lens on the camera. Do not forget to connect the lens cable at this time.
- 2** Set the lens iris to manual, and open the iris.
- 3** Set the lighting in such a way that the appropriate video output level is obtained at a distance of about 10 ft (3 meters) from the flange back adjustment chart. If the video level is too high, use a filter or shutter.
- 4** Loosen the screw that secures the F.f (flange focus) ring.
<Note>
Depending on the lens concerned, this ring may be marked as the "F.b" (flange back) ring.
- 5** Set the zoom ring to the telephoto position either by manual or electrical means.
- 6** Shoot the flange back adjustment chart, and turn the distance ring to adjust the focus.
- 7** Set the zoom ring to the wide-angle position, and turn the F.f ring to adjust the focus. Take care not to move the distance ring.
- 8** Repeat steps 5 to 7 until the chart is focused properly at both the telephoto and wide-angle positions.
- 9** Tighten up the screw that secures the F.f ring.

Performing the viewfinder adjustments

(The viewfinder is an optional accessory.)

Attaching the viewfinder

- 1 Check that the camera's POWER switch is at the OFF position.
- 2 Attach the accessory mounting plate to the viewfinder.

Remove mounting plate from the viewfinder

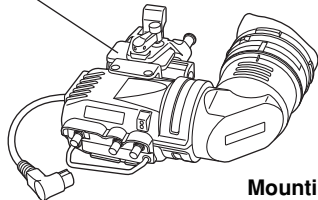

Mounting plate supplied to AK-HC930P

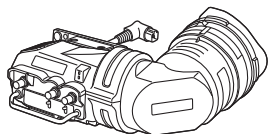
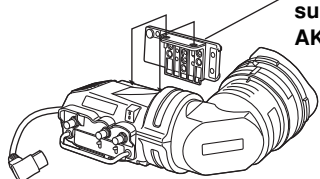

- 3 Pull up the knob on the mounting plate and slide the plate to attach the viewfinder.

Pull up the knob

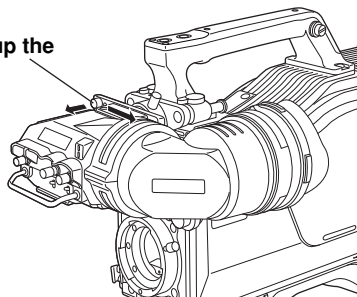

- 4 Tighten the stopper screw securely.

Stopper screw

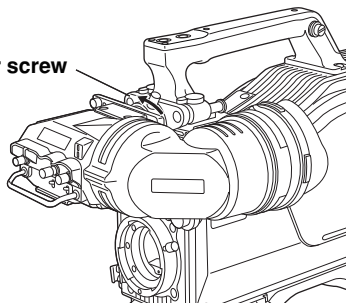

- 5 Connect the plug to the viewfinder's connector.

<Note>

When connecting the plug to the viewfinder's connector, ensure that it is fully and securely inserted.

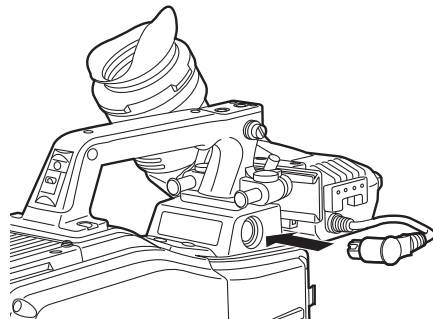

Detaching the viewfinder

- 1 Check that the camera's POWER switch is at the OFF position.
- 2 Loosen the stopper screw, pull up the knob on the mounting plate and slide the viewfinder along and off the plate.

Stopper screw
Pull up the knob

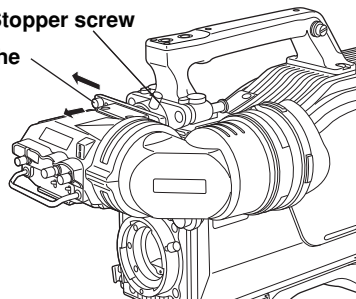

- 3 Disconnect the plug from the viewfinder cable connector.

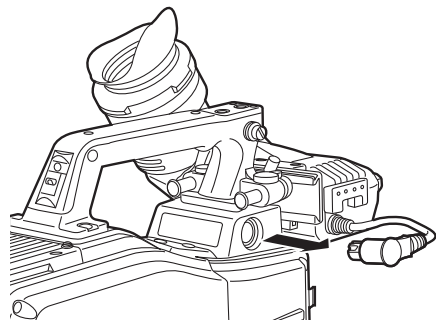

Performing the viewfinder adjustments

(The viewfinder is an optional accessory.)

Left or right position adjustment

- 1 Loosen the stopper screw.

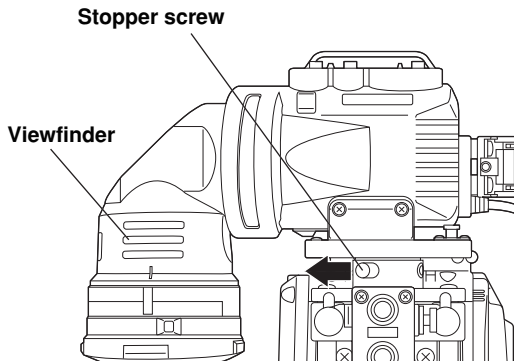

- 2 Move the viewfinder to the left or right to adjust its position.

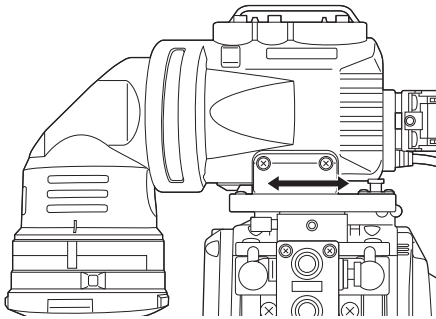

- 3 Tighten the stopper screw.

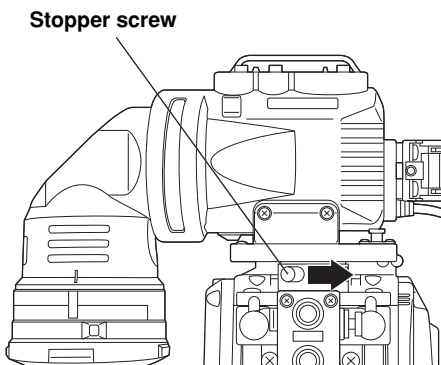

Forward or backward position adjustment

- 1 Rotate the viewfinder forward/backward position fixing lever towards the outside to release it from the locked position.

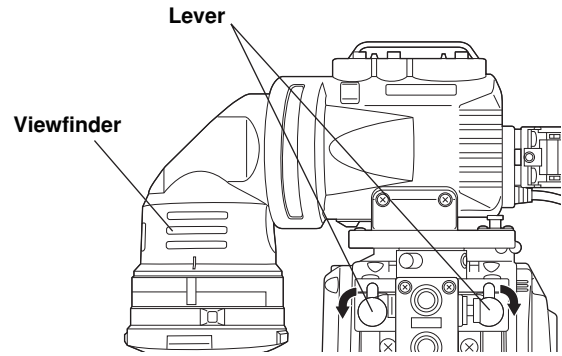

- 2 Move the viewfinder forward or backward to adjust its position.

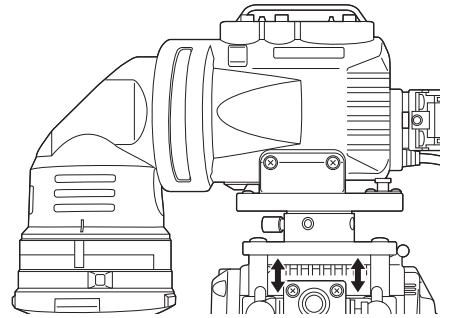

- 3 Rotate the viewfinder forward/backward position fixing lever in the opposite direction until it locks.

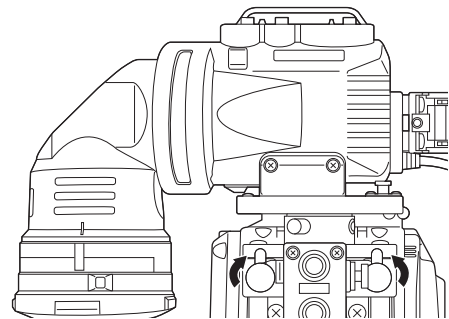

Connecting a microphone

When the microphone is mounted on the viewfinder (optional accessory) for use

The microphone of the microphone kit AJ-MC700P (optional accessory) can be mounted on the viewfinder.

- 1 Open the microphone holder.

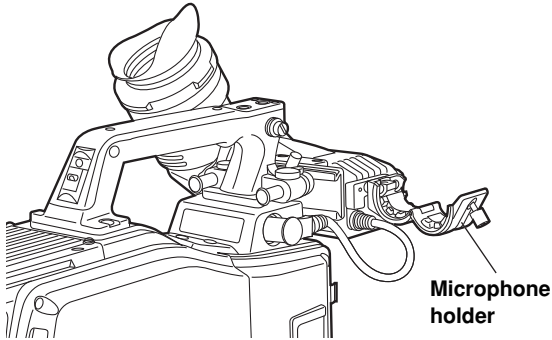

- 2 Mount the microphone and tighten up the clamp screw.

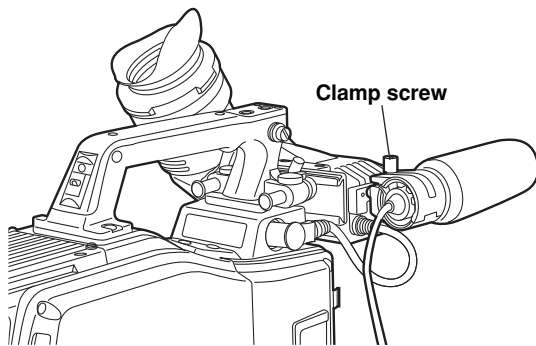

- 3 Connect the microphone cable to the MIC IN connector on the camera.

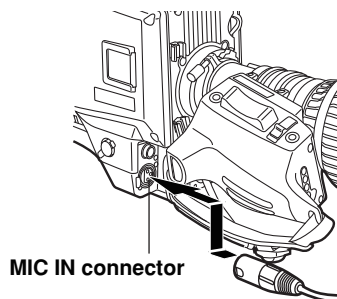

- 4 If the audio channel whose signals are to be recorded so requires, set the AUDIO IN switch to F.

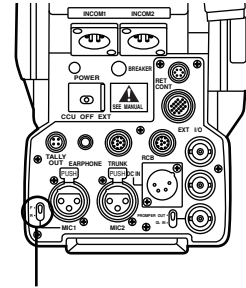

AUDIO IN switch

Mounting the camera on a tripod

Use the tripod attachment, available as an optional accessory, to mount the camera on a tripod.

- 1 Mount the tripod attachment on the tripod.
<Note> Consider the center of gravity of the camera and tripod together when selecting the holes for attaching the camera. Check that the diameter of the selected holes match the diameter of the screws on the tripod platform.

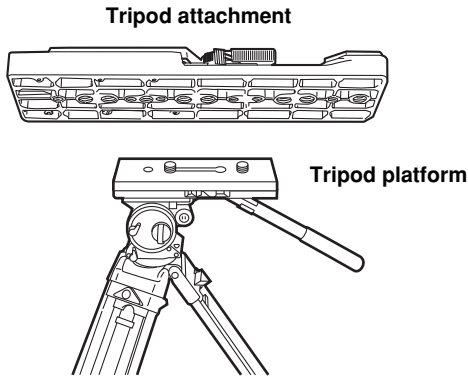

- 2 Mount the camera on the tripod attachment. Slide the camera toward the front along the groove until a click is heard.

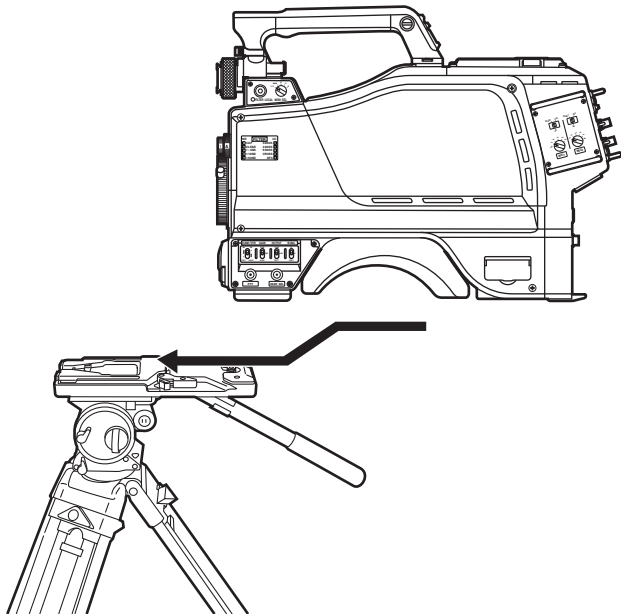

Detaching the camera from the tripod attachment

While pushing the red lever, move the black lever in the direction of the arrow, and slide the camera toward the back.

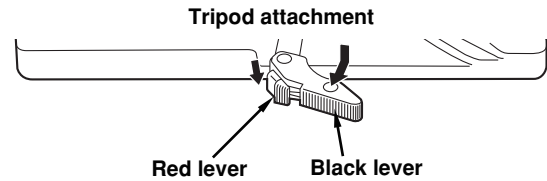

<Note>

If the pin of the tripod attachment fails to return to its original position after the camera has been detached, push the red lever again and simultaneously move the black lever in the direction of the arrow to return the pin to its original position.

Bear in mind that the camera cannot be mounted if the pin still remains at the center.

Component system configuration

An example of the standard system consisting of the Multi-Format Camera (AK-HC930P) and peripheral components is described below and shown on the following page. The MSU (AK-MSU930P) is not required unless a multiple number of cameras are to be controlled.

The basic system configuration includes the lens, Multi-Format Camera, 2" viewfinder, camera control unit (CCU) and remote operation panel (ROP).

System block diagram

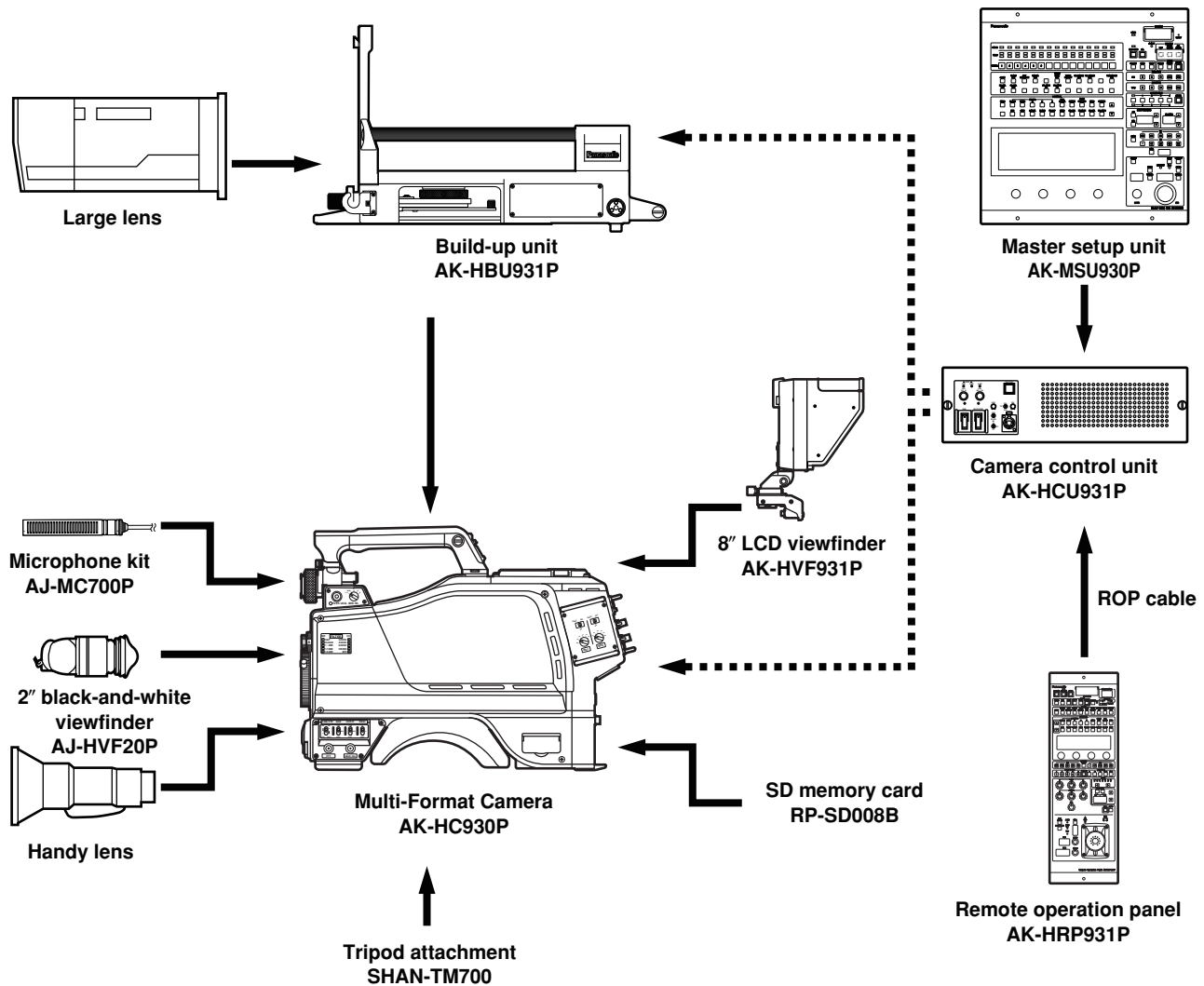

Component system configuration

Outline of peripheral components

1 Camera control unit (CCU: AK-HCU931P)

This is the Multi-Format Camera's camera control unit. It is connected to the Multi-Format Camera using an optical fiber cable (optional accessory).

As a standard feature, it supports SD video input and output, and it can also support HD video input and output by connecting the HD output unit (AK-HHD931P).

2 Remote operation panel (ROP: AK-HRP931P)

The ROP is connected to the CCU using the ROP cable (optional accessory), and enables the camera, CCU and lens to be operated by remote control.

3 Master setup unit (MSU:AK-MSU930P)

When a multiple number of cameras and CCUs are used, the MSU can operate up to 15 units either separately or simultaneously by remote control. It can be operated together with the ROP.

4 2" viewfinder (2"VF: AJ-HVF20P)

This is the viewfinder for the Multi-Format Camera.

5 Build-up unit (AK-HBU931P)

This is an adapter used to mount a larger lens (optional accessory) on the Multi-Format Camera. Thereby, it affords the same level of operability as that provided by a larger camera.

6 LCD viewfinder (LCD VF: AK-HVF931P)

This is the LCD viewfinder for the Multi-Format Camera. It can be used at the same time as the 2" viewfinder. It can still be operated when the system is built up.

Component connections in an SD system

1 Component connections

Refer to pages 18 to 20 for the component connections.

After all the components have been connected (the monitor system may be connected afterward), set the CCU's main power switch to the ON position. Then turn on the camera's power switch.

System connections 1 (with Multi-Format Camera)

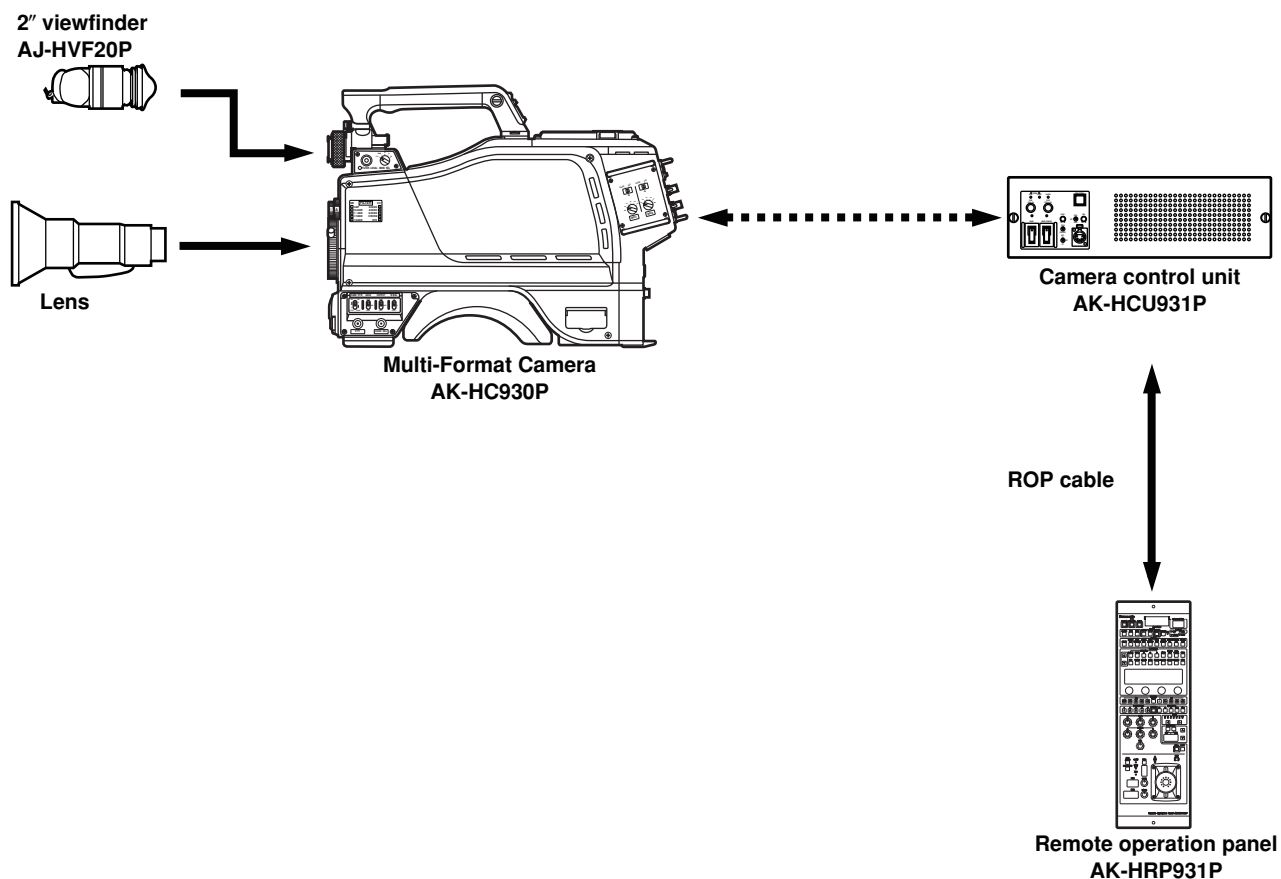

- ① Before proceeding with the connections, set the CCU power switch to the OFF position.
- ② Connect the Multi-Format Camera to the CCU.
- ③ Connect the ROP cable to the CCU and ROP.
- ④ When the camera power switch is set to ON after the CCU main power switch has been set to ON, the camera can be controlled using the ROP.
- ⑤ Upon completion of shooting, set the CCU camera power switch and main power switch to OFF.

System connections 2 (with build-up unit)

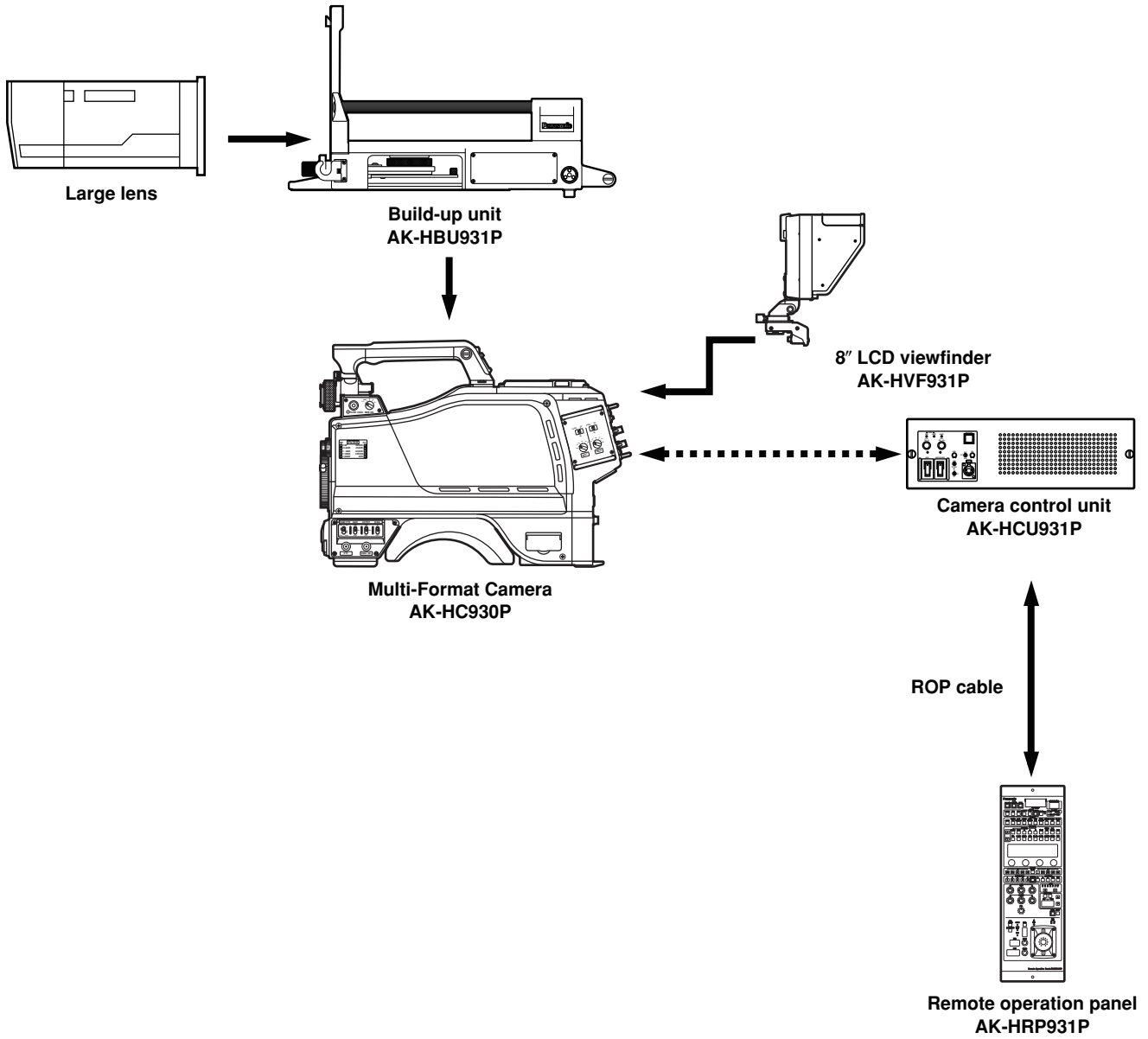

System connections 3 (with MSU)

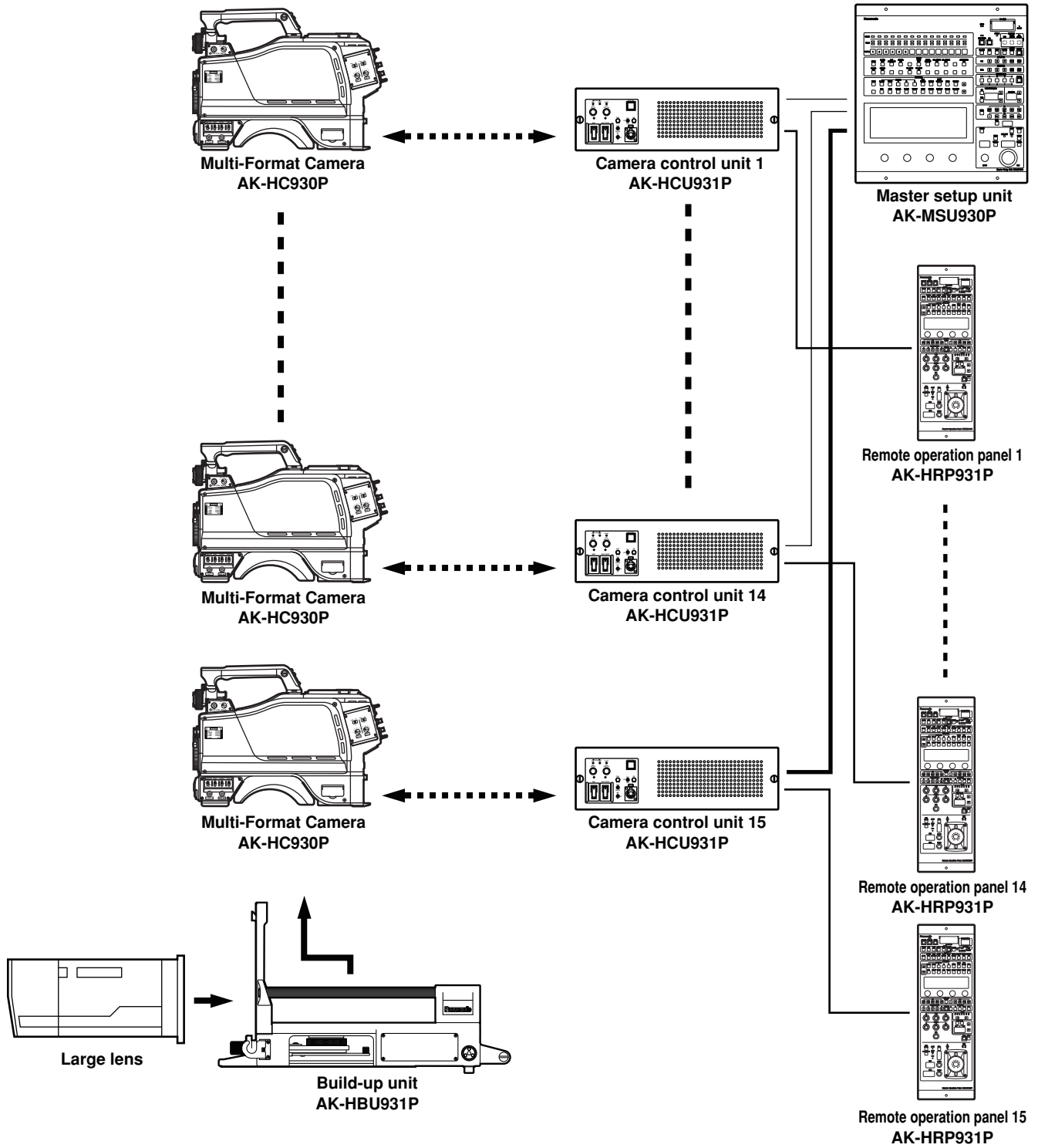

- A multiple number of cameras (up to 15 units) can be controlled in one location using the MSU.
- The cameras can be controlled by both the ROPs and MSU.

Status displays on viewfinder screen

Besides the images, Multi-Format Camera settings and messages indicating operating statuses appear on the viewfinder screen. In addition, the center marker and safety zone markers are also displayed.

The setting menu VF DISPLAY screen and the items which have been set to ON using the switches related to the viewfinder display appear at the top and bottom of the screen.

When a setting has been changed or an adjustment made, a message with details of the setting, the status of the adjustment process or the adjustment result can be displayed for about 3 seconds.

Display items and where the items appear

- ① Extender display
- ② Shutter speed/mode display
- ③ RET SEL display
- ④ Battery voltage display
- ⑤ Filter display
- ⑥ White balance memory display
- ⑦ Gain display
- ⑧ Audio CH1 and CH2 displays
- ⑨ Iris f-number display
- ⑩ Camera warning or message display
- ⑪ Focus position display
- ⑫ Zoom position display
- ⑬ MONI SEL display
- ⑭ Optical level display

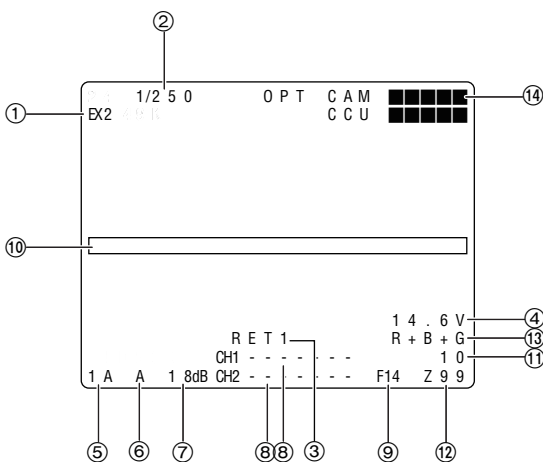

- ① **Extender display:**
This appears when the lens extender is being used.
- ② **Shutter speed/mode display:**
This indicates the shutter speed or shutter mode setting.
- ③ **RET SEL display:**
This indicates the return mode selected by the RET selector switch.
- ④ **Battery voltage display:**
This indicates the voltage of the battery currently in use.
- ⑤ **Filter display:**
This indicates the type of filter selected.
- ⑥ **White balance memory display:**
This indicates the automatic adjustment memory selected for the white balance.
A: The WHITE BAL switch is set to "A."
B: The WHITE BAL switch is set to "B."
P: The WHITE BAL switch is set to "PRST."
- ⑦ **Gain display:**
This indicates the video amplifier's gain setting (in dB) which has been selected by the GAIN switch.
- ⑧ **Audio CH1 and CH2 displays:**
The audio levels are displayed here (separately for audio CH1 and audio CH2).
- ⑨ **Iris f-number display:**
The approximate value of the iris setting (f-number) is displayed here.
<Note>
This display appears when a lens which has an f-number voltage output is being used.
- ⑩ **Camera warning or message display:**
A message indicating the occurrence of an alarm, the camera settings, the progress made in the adjustments, and the adjustment results appear here for about 3 seconds.
- ⑪ **Focus position display:**
The focus position is indicated here in the form of a number.
<Note>
This display appears only when a lens which has a focus position voltage output is being used.
- ⑫ **Zoom position display:**
The zoom position is indicated here in the form of a number.
<Note>
This display appears only when a lens which has a zoom position voltage output is being used.
- ⑬ **MONI SEL display:**
This indicates the video mode of the monitor output.
- ⑭ **Optical level display:**
This indicates the light sensing level of the optical fiber cable.

Menu operations

Basic setting menu operations

■ Displaying the menus

User menu

- 1 Press the MENU button.
The camera's USER menu screen now appears on the viewfinder or monitor.

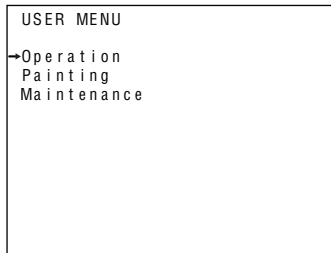

- 2 Turn the JOG dial to select the menu item.
- 3 After having selected the item, press the JOG dial to access that item's menu.

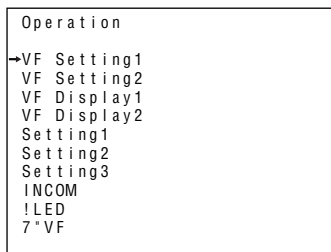

■ Entering the menu data

After accessing the item menus, enter the respective data.

- 1 Turn the JOG dial to select the menu item to be set.

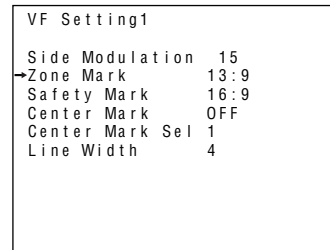

- 2 When the JOG dial is pressed, the setting of the item indicated by the arrow flashes.

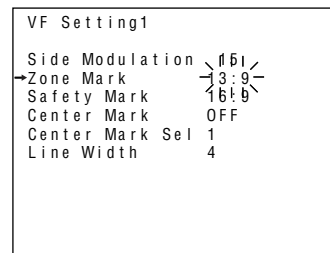

- 3 Turn the JOG dial to change the setting.

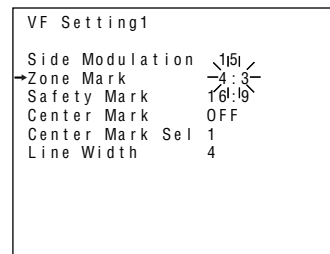

- 4 When the JOG dial is pressed, the data is entered.

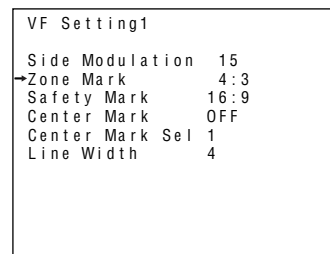

<Note>

Bear in mind that if, in step 3, the MENU switch is set to OFF while the setting is flashing, the setting prior to the flashing will remain unchanged.

Menu operations

■ Entering the menu data (continued)

When the setting flashes one character at a time, press the JOG dial to move the flashing toward the right.

- 1 When the JOG dial is pressed, flashing moves toward the right.

```
Cam Setting3
→RET ID RET1 : ABCD1001
RET ID RET2  : EFGH2001
RET ID RET3  : IJKL3001
RET ID RET4  : WXYZ4001
```



```
Cam Setting3
→RET ID RET1 : ABCD1001
RET ID RET2  : EFGH2001
RET ID RET3  : IJKL3001
RET ID RET4  : WXYZ4001
```

- 2 Turn the JOG dial to change the setting.

```
Cam Setting3
→RET ID RET1 : AMCD1001
RET ID RET2  : EFGH2001
RET ID RET3  : IJKL3001
RET ID RET4  : WXYZ4001
```

- 3 When the JOG dial is now pressed, the data is entered.

```
Cam Setting3
→RET ID RET1 : AMCD1001
RET ID RET2  : EFGH2001
RET ID RET3  : IJKL3001
RET ID RET4  : WXYZ4001
```

Setting menu configuration

Hierarchical menus

Operation

VF Setting1 Viewfinder settings1	<ul style="list-style-type: none"> — Side Modulation (for changing the brightness level of the signals outside the zone markers) — Zone Mark (13:9/4:3/OFF) (for setting the zone markers) — Safety Mark (16:9/4:3/OFF) (for setting the safety markers) — Center Mark (for setting the center marker) — Center Mark Sel (for setting the shape of the center marker) — Line Width (for changing the thickness of the VF markers)
VF Setting2 Viewfinder settings2	<ul style="list-style-type: none"> — VF DTL (for adjusting VF DTL) — HD Peak Freq (for adjusting the peak frequency of HD RET signal) — HD OFFSET Gain (for adjusting the DTL offset gain of HD RET signal) — HD CRISP (for adjusting the DTL crisp level of HD RET signal) — D1 Peak Freq (for adjusting the peak frequency of D1 RET signal) — D1 OFFSET Gain (for adjusting the DTL offset gain of D1 RET signal) — D1 CRISP (for adjusting the DTL crisp level of D1 RET signal) — VBS Peak Freq (for adjusting the peak frequency of VBS RET signal) — VBS OFFSET Gain (for adjusting the DTL offset gain of VBS RET signal) — VBS CRISP (for adjusting the DTL crisp level of VBS RET signal)
VF Display1 Viewfinder display settings	<ul style="list-style-type: none"> — F Number (for setting the f-number display setting to ON or OFF) — ZOOM (for setting the zoom value display to ON or OFF) — FOCUS (for setting the focus value display to ON or OFF) — EXTENDER (for setting the lens extender display to ON or OFF) — MONI OUT (for setting the monitor selection output display to ON or OFF) — FILTER (for setting the CC/ND filter display to ON or OFF) — M GAIN (for setting the gain display to ON or OFF) — SHUTTER (for setting the electronic shutter display to ON or OFF) — 5600K (for setting the D5600K display to ON or OFF) — AUDIO LEVEL (for setting the audio level display to ON or OFF)
VF Display2 Viewfinder display settings	<ul style="list-style-type: none"> — OPT LEVEL (for setting the optical level display to ON or OFF) — RET SEL (for setting the DET selection display to ON or OFF) — STATUS (for setting the display appearing when functions are selected to ON or OFF) — ALARM (for setting the alarm display to ON or OFF) — FRAME RATE (for setting the frame rate display to ON or OFF) — VOLTAGE (for setting the supply voltage display to ON or OFF) — COLOR TEMP (for setting the color temperature display to ON or OFF) — White Ch (for setting the white balance memory)
Setting1 Camera settings1	<ul style="list-style-type: none"> — FAN POWER (for setting the camera fan to ON or OFF) — FAN MODE (for setting the camera fan mode) — USER SW (for setting the user switch) — OUTPUT SEL (for setting the analog output to Y/Pb/Pr or RGB) — H PHASE (for setting the horizontal phase) — CABLE COMP (for setting the analog output cable compensation)
Setting2 Camera settings2	<ul style="list-style-type: none"> — VTR/RET_SEL (for setting the VTR/RET SEL SW function) — GRIP RET 1 (for setting the grip RET1 SW function) — GRIP RET 2 (for setting the grip RET2 SW function) — HND LNS VTR (for setting the handy lens VTR SW function) — HND LNS RET (for setting the hand-held lens return SW function) — STD LNS RET1 (for setting the standard lens RET 1 SW function) — STD LNS RET2 (for setting the standard lens RET 2 SW function) — EXT RET1 (for setting the external return control SW1 function) — EXT RET2 (for setting the external return control SW2 function) — RET MODE (for setting the return SW operation mode)
Setting3 Camera settings3	<ul style="list-style-type: none"> — RET ID RET1 (for setting the RET1 designation) — RET ID RET2 (for setting the RET2 designation) — RET ID RET3 (for setting the RET3 designation) — RET ID RET4 (for setting the RET4 designation) — GAIN SW LOW (for setting the gain SW to LOW gain) — GAIN SW MID (for setting the gain SW to MID gain) — GAIN SW HIGH (for setting the gain SW to HIGH gain) — ID NUMBER (for setting the camera number and designation)
INCOM INCOM settings	<ul style="list-style-type: none"> — CH1 ENG/PD (for switching INCOM1) — CH2 ENG/PD (for switching INCOM2) — CH1 CCU/CRANE (for switching crane INCOM) — CH2 CCU/CRANE (for switching crane INCOM)
ILED Camera status display settings	<ul style="list-style-type: none"> — GAMMA OFF (for displaying the status when the gamma is OFF) — SHUTTER (for displaying the status when the electronic shutter is ON) — EXTENDER (for displaying the status when the extender is ON) — MONI OUT (for displaying the status when the monitor output signal is other than Y) — FAN OFF (for displaying the status when the fan is OFF) — GAIN (for displaying the status when the gain is other than 0 dB) — BLACK GAMMA (for displaying the status when the black gamma is ON)
7"VF	<ul style="list-style-type: none"> — VF FAN SPEED (for controlling the fan speed of the 7" viewfinder)

Setting menu configuration

Hierarchical menus

Painting

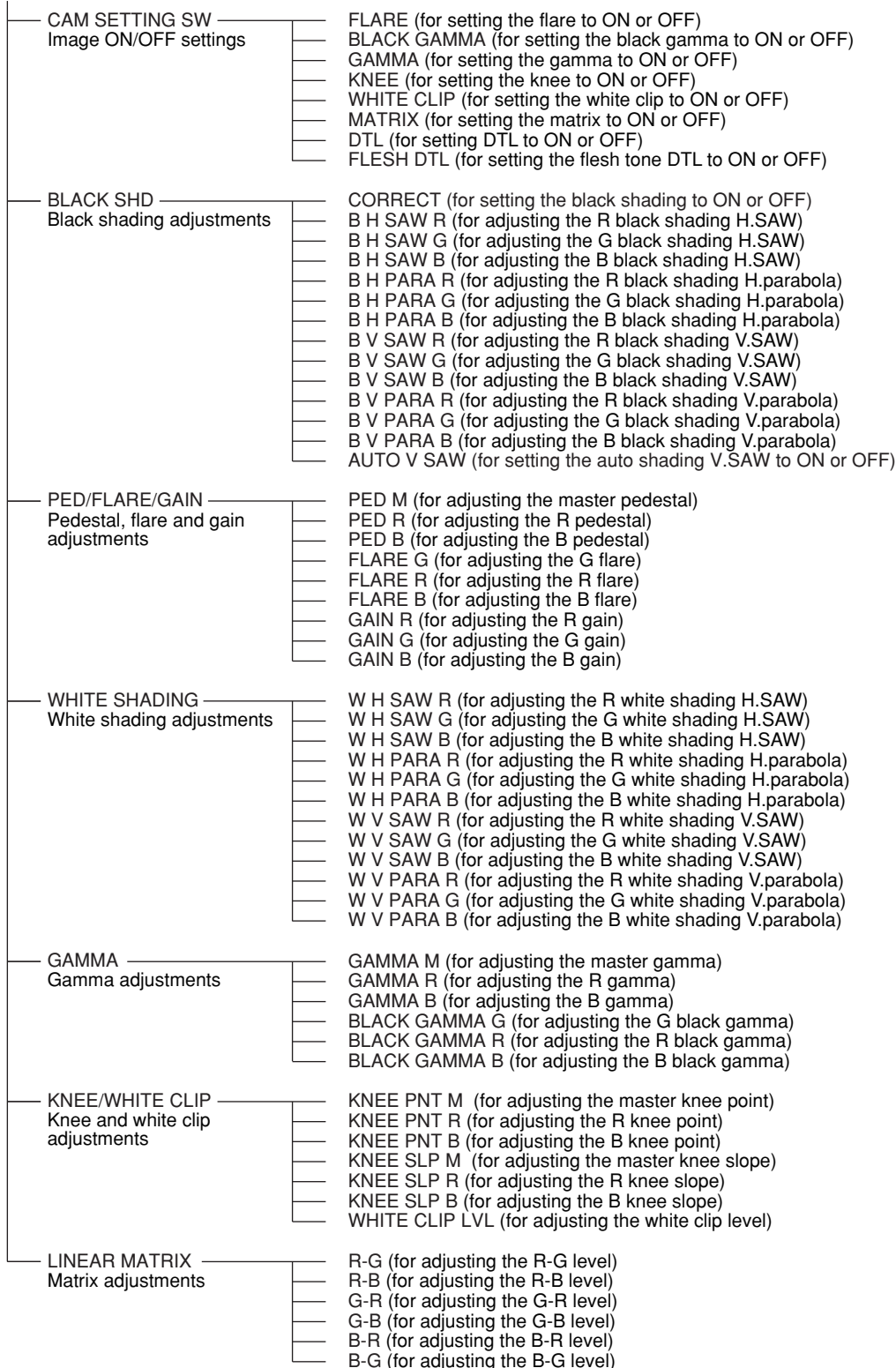

Setting menu configuration

Hierarchical menus

Painting

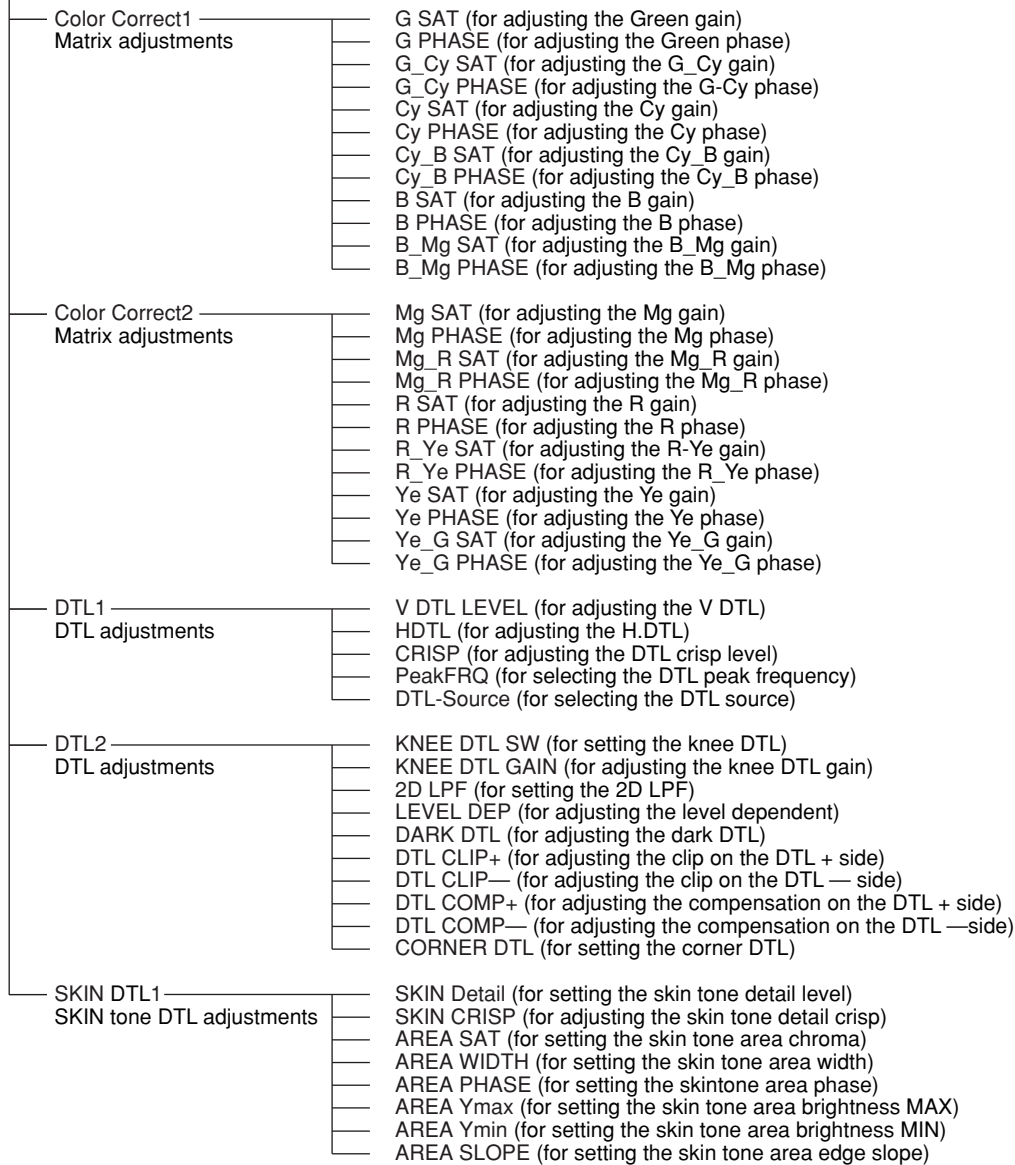

Maintenance

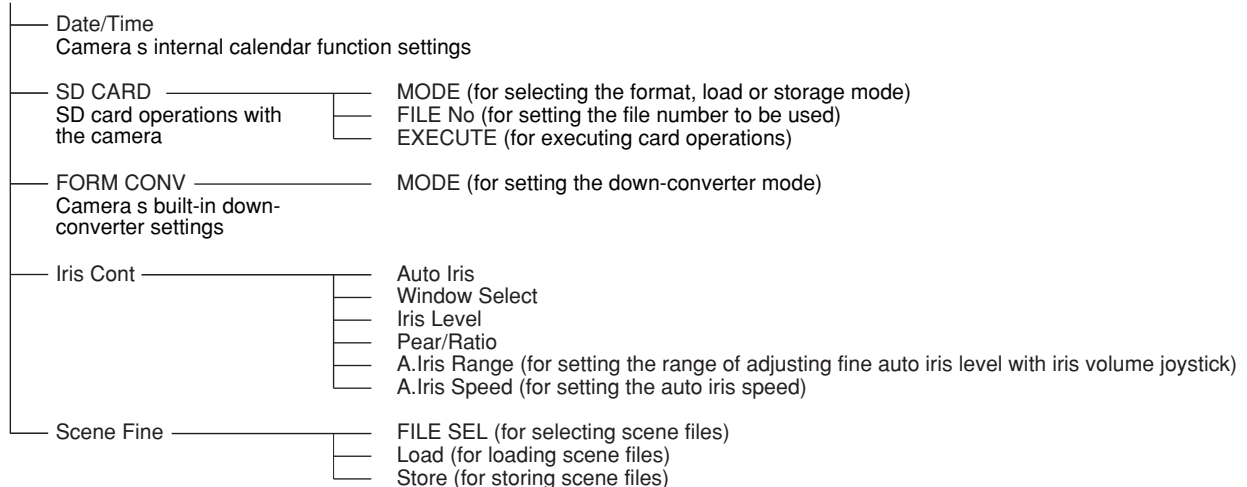

AK-HC930P Connector pin assignment

CN# in the Instructions

③ OPT FIBER EDW.3K.93C.TLC (Hirakawa)

Pin#	Signal
01	OPT-TX (Mark Band = IN)
02	OPT-RX (Mark Band = OUT)
1	STBYINCOM-T
2	STBYINCOM-R
3	AC220V(C)
4	AC220V(H)

④ INCOM XLR5-31F77 Female (Canon)

Pin#	Signal
1	TALK_GND
2	TALK
3	RECEIVE_GND
4	RECEIVE
5	PGM

⑩ RET CONT HR10A-7R-6SC (Hirose)

Pin#	Signal
1	INCOM1_MIC_ON
2	INCOM2_MIC_ON
3	AGND
4	RET_CNT3
5	RET_CNT1
6	RET_CNT2

⑪ EXT I/O HR10A-13R-20SC (Hirose)

Pin#	Signal
1	BUILT_UP_ACT
2	AGND
3	RET_EXT1
4	RET_EXT2
5	RET_EXT3
6	DGND
7	CAMDATA-R
8	CAMCONT-R
9	EXT+12V
10	UNREG_GND
11	MONI-OUT
12	MONI-OUT_GND
13	
14	
15	
16	IRIS_CONT
17	IRIS_POSI
18	ZOOM_POS
19	FOCUS_POS/L_RXD
20	S_IRIS_A-R/L_TXD

⑫ HD SDI BNC(75)J-PL72J-BPA (Hirose)

Pin#	Signal
1	SDI_OUT
2	SDI_OUT_GND

⑬ AUX OUT BNC(75)J-PL72J-BPA (Hirose)

Pin#	Signal
1	AUX_OUT
2	AUX_GND

⑭ PROMPT/GL VJS1440

Pin#	Signal
1	PROMPT/GL_IN
2	PROMPT_GND/GL_IN_GND

CN# in the Instructions

⑮ RCB HA10A-10R-10SC (Hirose)

Pin#	Signal
1	CAM_DATA(H)
2	CAM_DATA(C)
3	CAM_CONT(H)
4	CAM_CONT(C)
5	
6	ECU_ON
7	
8	
9	RCOP+12V
10	UNREG_GND

⑯ DC IN HA16RA-4P (Hirose)

Pin#	Signal
1	EXT_GND
2	
3	
4	EXT+12V

⑰ MIC1 HA16PRM-3SB(05) (Hirose)

Pin#	Signal
1	MIC1_GND
2	MIC1(H)
3	MIC1(C)

⑱ MIC2 HA16PRM-3SB(05) (Hirose)

Pin#	Signal
1	MIC2_GND
2	MIC2(H)
3	MIC2(C)

⑳ TALLY OUT HR10A-7R-4SC (Hirose)

Pin#	Signal
1	UNREG_GND
2	R_TALLY_OUT
3	G_TALLY_OUT
4	SCRIPT+12V

㉑ EARPHONE VJJ0522

Pin#	Signal
1	PHONE_GND
2	PHONE_OUT
3	

㉒ TRUNK HR10A-10R-12SC (Hirose)

Pin#	Signal
1	CMD-OUT0(H)
2	CMD-OUT0(C)
3	CMD-IN0(H)
4	CMD-IN0(C)
5	CMD-OUT1(H)
6	CMD-OUT1(C)
7	CMD-IN(H)
8	CMD-IN1(C)
9	
10	DGND
11	
12	

㉓ LENS HR10A-10R-12SC (Hirose)

Pin#	Signal
1	LENS_RET SW
2	LENS_VTR SW
3	AGND
4	ENF_SERVO
5	IRIS_CONT
6	LENS+12V
7	IRIS_POSI
8	H_IRIS_A-R
9	EXTENDER
10	ZOOM_POSI
11	FOCUS_POS/L_RXD
12	S_IRIS_A-R/L_TXD

CN# in the Instructions

⑤⑥ FRONT MIC HA16PRM-3S(05) (Hirose)

Pin#	Signal
1	FRONT_MIC_GND
2	FRONT_MIC(H)
3	FRONT_MIC(C)

⑤⑦ VF HR12-14RA-20SC (Hirose)

Pin#	Signal
1	VF+12V
2	VF+12V
3	UNREG_GND
4	VF-PBOUT_GND
5	VF-PBOUT_GND
6	VF-YOUT
7	VF-YOUT_GND
8	VF_CLK
9	VF_WR
10	VF_DATA
11	UNREG_GND
12	ZEBRA_SW
13	PEAKING
14	TA_BOX_ACT
15	VF-PROUT
16	VF-PBOUT
17	VF_SW3
18	FRONT_VR
19	TA_TALLY
20	F_GND

⑤⑧ MONITOR OIVJS1440

Pin#	Signal
1	MONI_OUT
2	MONI_OUT_GND

⑤⑨ REAR VF CN D02-29S-N-F0 (JAE)

Pin#	Signal
1	VF-YOUT
2	VF-PBOUT
3	VF-PROUT
4	
5	12C_DATA
6	R_TALLY2
7	TA_TALLY
8	
9	LCD+12V
10	LCD+12V
11	VF-YOUT_GND
12	VF-PBOUT_GND
13	VF-PROUT_GND
14	AGND
15	DGND
16	
17	UNREG_GND
18	
19	F_GND
20	LCD_ACT
21	
22	
23	PEAKING CONT
24	
25	G_TALLY2
26	VF_P_REQ
27	
28	
29	

External dimension drawings

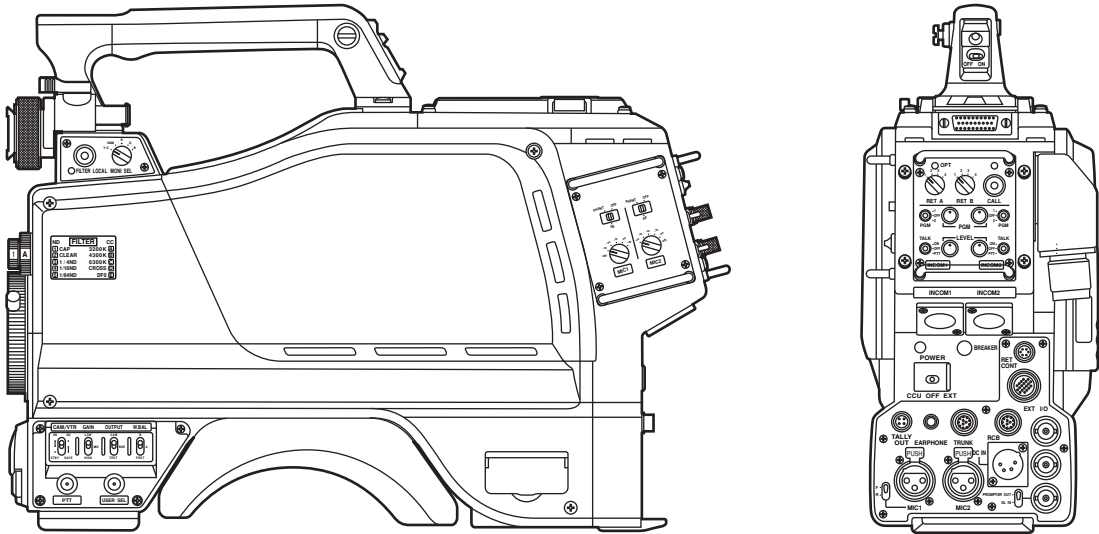
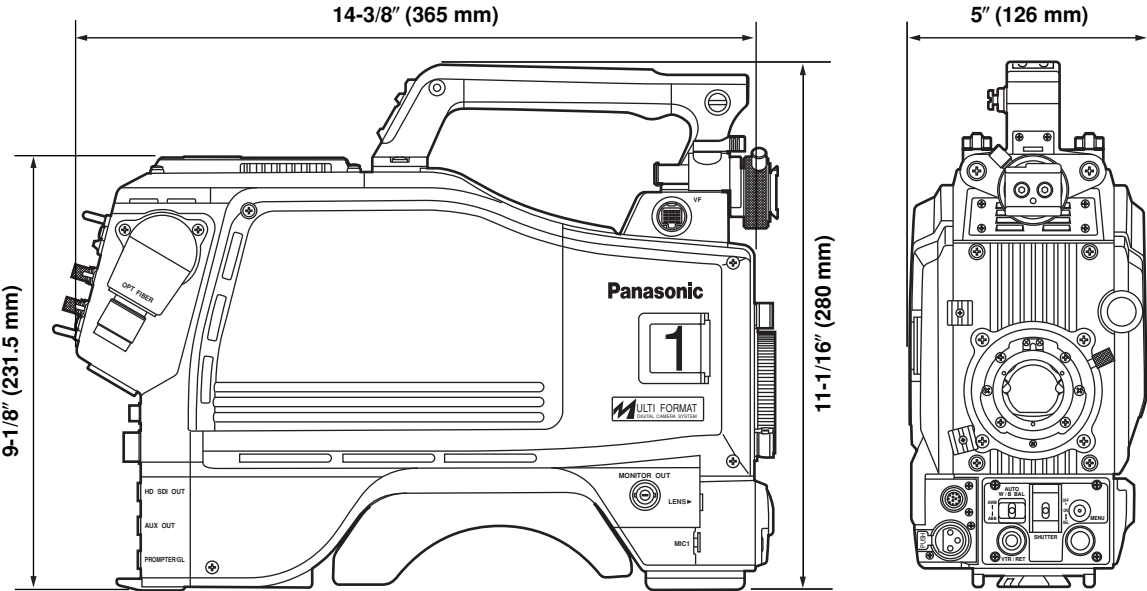

Specifications

Power supply:	DC 12 V (when external power is supplied) AC 150 V–240 V (when CCU is connected)
Power consumption:	33 W (during external power supply operation) 43 W (when CCU is connected)

 indicates safety information.

Operating temperature range:	32°F to 104°F (0°C to +40°C)
Storage temperature range:	–4°F to 140°F (–20°C to +60°C)
Operating ambient humidity:	Less than 85%
Weight:	Approx. 10.7 lbs (4.85 kg)
Dimensions:	5 (W)×11-1/16 (H)×14-3/8 (D) inch (excluding protrusions) 126 × 280 × 365 mm

Basic items

- 1) Pickup device: 2/3" 2.2 million pixel FITCCD x 3
- 2) System: GBR pickup system
- 3) Color separation optical system: f/1.4 prism
- 4) Optical filters: CC: 3200K, 4300K, 6300K, Cross Diffusion
ND: CAP, Through, 1/4, 1/16, 1/64
- 5) Lens mount: Bayonet type
- 6) Output standard: SMPTE 296M
- 7) Sensitivity: f/10.0, 2000 lux, 3200 K, white reflectance 89.9%
- 8) Horizontal modulation: More than 45% (27.5 MHz)
- 9) S/N ratio: 54 dB (Y: 30 MHz)
- 10) Horizontal frequency: 33.716 kHz, 1125-line frame
- 11) Vertical frequency: 59.94 Hz, interlace

Input/output signals

- 1) Mic input: –20, –30, –40, –50, –60 dBm
(XLR 3-pin female×2)
Gain selected by switch
- 2) INCOM: 0 dBm/600 ohms
(XLR 5-pin, female×2)
(Mixing is controlled separately for PGM1 and PGM2.)
- 3) Monitor output: HD signals = 1Vp-p, 75 ohms (BNC)
Output signals can be selected using the monitor output selector switch.
- 4) QTV output: VBS signal = 1 Vp-p, 75 ohms (BNC)
- 5) G/L input: 1 BNC connector (tri-level SYNC)
- 6) AUX output: VBS signal = 1 Vp-p, 75 ohms (BNC)
(when optional unit has been installed)

Control

- 1) Power selection: EXT, OFF, CCU
- 2) USER SEL: Functions specified by menu items can be allocated to the switch.
- 3) RET A/B selection: For selecting the return signal
- 4) Front tally selection: Front tally HIGH, LOW, OFF (VF unit)
- 5) Viewfinder marker selection: Center marker, safety zone, 4:3 marker
- 6) Gain selection: LOW, MID, HIGH
- 7) Output selection: CAM, BAR, TEST
- 8) White balance mode: A, B, preset
- 9) Shutter speed selection: 1/100, 1/125, 1/250, 1/500, 1/1000, 1/2000
- 10) AWB, ABB settings
- 11) Menu selection
- 12) CALL SW
- 13) INCOM: MIC ON/OFF, receive or PGM level
- 14) MIC setting: MIC power, MIC gain, MIC1 selection
- 15) Optical filter setting: REM, LOCAL selection and LOCAL setting

*When the CCU is connected, the selection functions for 6) to 10) are not effective.

Optional connectors

- 1) VTR output (26-pin male connector made by JAE)

Weight and dimensions shown are approximate.
Specifications are subject to change without notice.

Panasonic®

PANASONIC BROADCAST & TELEVISION SYSTEMS COMPANY
UNIT COMPANY OF PANASONIC CORPORATION OF NORTH AMERICA

Executive Office:

One Panasonic Way 4E-7, Secaucus, NJ 07094 (201) 348-7000

EASTERN ZONE:

One Panasonic Way 4E-7, Secaucus, NJ 07094 (201) 348-7621

Southeast Region:

1225 Northbrook Parkway, Ste 1-160, Suwanee, GA 30024 (770) 338-6835

Central Region:

1707 N Randall Road E1-C-1, Elgin, IL 60123 (847) 468-5200

WESTERN ZONE:

3330 Cahuenga Blvd W., Los Angeles, CA 90068 (323) 436-3500

Government Marketing Department:

52 West Gude Drive, Rockville, MD 20850 (301) 738-3840

Broadcast PARTS INFORMATION & ORDERING:

9:00 a.m. – 5:00 p.m. (PST) (800) 334-4881/24 Hr. Fax (800) 334-4880

Emergency after hour parts orders (800) 334-4881

TECHNICAL SUPPORT:

Emergency 24 Hour Service (800) 222-0741

Panasonic Canada Inc.

5770 Ambler Drive, Mississauga, Ontario L4W 2T3 (905) 624-5010

Panasonic de Mexico S.A. de C.V.

Av angel Urraza Num. 1209 Col. de Valle 03100 Mexico, D.F. (52) 1 951 2127

Panasonic Puerto Rico Inc.

San Gabriel Industrial Park, 65th Infantry Ave., Km. 9.5, Carolina, Puerto Rico 00630 (787) 750-4300

© 2006 Matsushita Electric Industrial Co., Ltd. All rights reserved.